

EE 333
Exam 1
Summer 2003

Name _____

Instructions: The points allocated to each problem are as indicated. All work and answers should be written on the exam sheet itself. Unless specifically stated to the contrary, assume all operational amplifiers are ideal.

Problem 1 (15 pts). Determine the 3dB bandwidth in Hz. of the amplifiers shown. Assume the GB of the op amps is 4 MHz.

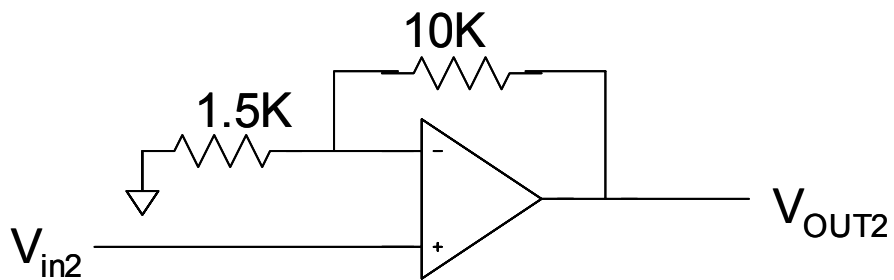
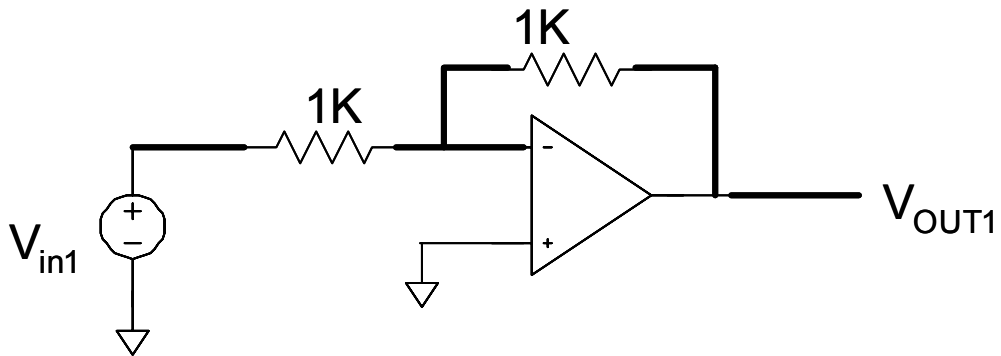

Problem 2 (15 pts) Determine the steady state output for the amplifier shown if the input is $V_{IN} = 3\sin(800t + 35^\circ)$.

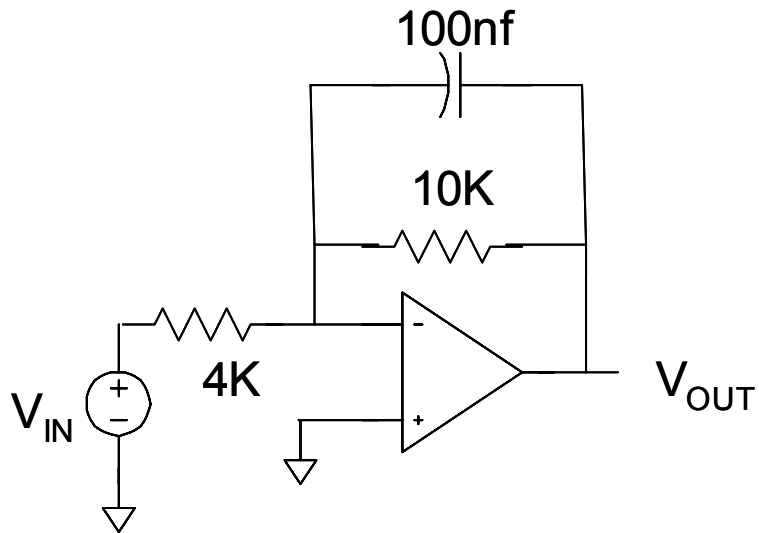

Problem 3 (15 points)

For the following circuit

- a) Determine the poles and zeros for the following circuit.
- b) Determine the 3dB bandwidth

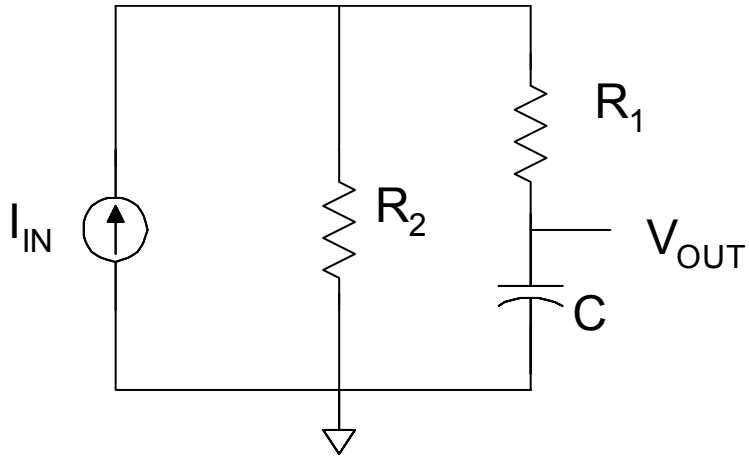

Problem 4 (15 pts)

A voltage amplifier with a gain of 40dB has an input impedance of $100\text{K}\Omega$ and an output impedance of 500Ω . Assume an excitation of 3V RMS and source impedance of 20K is input into the amplifier and the amplifier is driving a $2\text{K}\Omega$ load.

- a) What is the RMS output voltage of the amplifier?
- b) Quantitatively compare the actual output voltage with that you would expect if the amplifier were ideal.

Problem 5 (15 pts) For the following circuit obtain V_{OUT} in either the s-domain or the phasor domain in terms of the two inputs. If you chose to do this in the s-domain, assume V_{in1} and V_{in2} are s-domain inputs and if you chose to do this in the phasor domain, assume V_{in1} and V_{in2} are phasor-domain inputs.

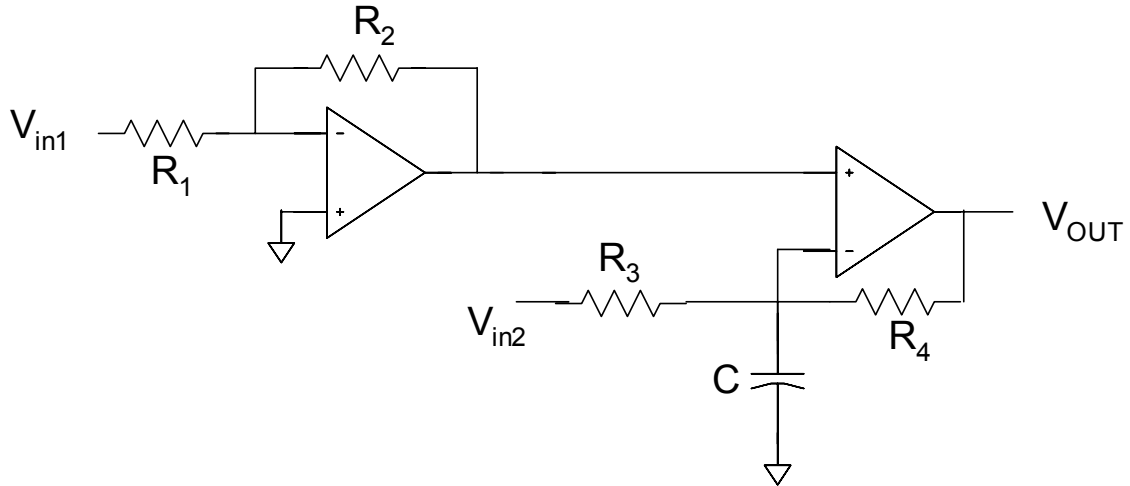

Problem 6 (15 pts) Determine the input impedance for the following circuit.

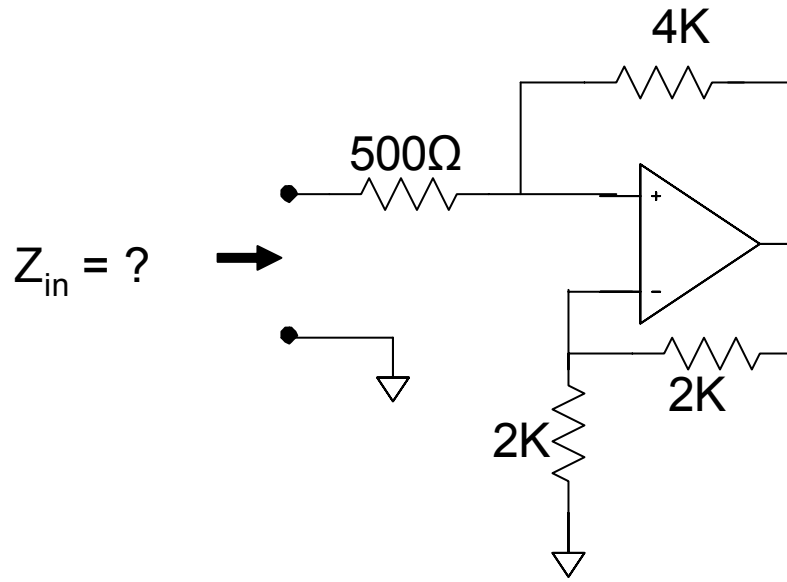

Problem 7 (10 pts) Design a circuit that has an output voltage given by the expression $V_{\text{OUT}} = 4V_1 - V_2 + \frac{2V_4}{S}$. Assume you have available ideal op amps, resistors, capacitors and ideal voltage sources.